



CAPACITY DEALER HANDBOOK



CAPACITY

TABLE OF CONTENTS

1. ABOUT US

- Company Overview
- Our Facility
- Our Brand

2. CONTACTS

3. DEALER SUCCESS FACTORS

4. DEALER POLICIES & PROCEDURES

- Payment & Shipment Options
- Changes to Existing Orders
- Truck Cancellation Policy
- Conquest Incentive
- Co-op Advertising
- Ship In/Delivery Allowance

5. WARRANTY

- Introduction
- Definitions of Warranty
- Warranty Policy Updates
- Standard Warranty Terms
- Warranty Statement
- Warranty Terms & Conditions
- New Vehicle Warranty
- Mainframe and Boom Warranty
- Paint Limited Warranty
- Warranty Claims Process

6. CAPACITY BASE TRUCK SPECIFICATIONS

7. AFTERMARKET PARTS

- Terms & Conditions
- Parts Return Policy

8. BRAND USE GUIDELINES



ABOUT US

ABOUT US

Company Overview

Since our establishment in 1974, Capacity Trucks has been an industry leader in the manufacturing of terminal trucks. We are known for our robust manufacturing that produces the most durable, long-lasting, power-horse work trucks in the industry. We also pride ourselves on having the unique ability to provide a high level of customization to meet our customers' specific work needs.

Today, Capacity Trucks is part of Terex Corporation, a global leader in specialized equipment solutions, serving essential sectors such as emergency services, waste and recycling, utilities and construction. Our dedication and collaborative spirit drive us to innovate, taking a customer-focused approach to increase efficiency and uptime profitability, while lowering the total cost of operation. At Capacity, our goal is to keep the world, and our customers, moving from the busiest ports, rail terminals, warehouse/distribution centers and beyond.

Our Facility

Capacity's 42-acre manufacturing facility is located in Longview, Texas. Our complex encompasses 150,000 square feet of manufacturing space, a 40,000-square-foot parts warehouse, quality inspection area and receiving facilities, as well as our corporate office.

We are proud that Capacity operates under ISO 9001 certification, which continually monitors the fabrication process, facilitating the build quality and integrity assurance of trucks. Additionally, we subscribe to the Lean Six Sigma manufacturing process methodologies and pledge continuous operational improvement and sustained excellence in the manufacture of our products.

Our Brand

At Capacity Trucks, we have stood the test of time, building our reputation upon the integrity of our people and the rugged durability of our products for over 50 years.

That rugged durability, along with the reliability of our products, is the reason customers count on Capacity year after year; it has contributed to our company's solid reputation in the industry. Our objective is to predict and fulfill the needs of our customers by adhering to the following tenants in our manufacturing:

- **Performance**—Capacity Trucks keeps the world moving with reliable, durable yard trucks that perform day in and day out. We commit to reliability by design and innovation in engineering.
- **Trust**—At Capacity Trucks, we have an unwavering commitment to building trusted, transparent relationships with our customers and dealers.
- **Innovation**—We are committed to continuously exploring new and better solutions and technologies to meet the changing needs of the marketplace and our customers.
- **Quality**—Our trucks set the standard in engineering excellence and manufacturing. We rigorously test our trucks and look for continuous improvements to ensure they can solidly perform to our customers' expectations.



CONTACTS

CONTACTS

CONTACTS



SALES & SERVICE TEAM

DIRECTOR OF SALES

Todd Gibson
Todd.Gibson@capacitytrucks.com
574.214.8906

REGIONAL SALES MANAGER

Brandon Fowler
Brandon.Fowler@capacitytrucks.com
903.806.7419

REGIONAL SALES MANAGER

Kevin Hebert
Kevin.Hebert@capacitytrucks.com
903.803.8099

REGIONAL SALES MANAGER

Will Seger
John.Seger@capacitytrucks.com
903.530.3313

SALES SUPPORT MANAGER

Carla Sexton
Carla.Sexton@capacitytrucks.com
903.424.7891

SALES COORDINATOR (Quotes, SOAs & Change Orders)

Tatiana Carrillo
Tatiana.Carrillo@capacitytrucks.com
903.931.7999

SALES SUPPORT (Shipping, BOLs, MSOs)

Brooke Clague
Brooke.Clague@capacitytrucks.com
903.315.0849

CONTACTS



SERVICE/PARTS TEAM

WARRANTY, SERVICE & PARTS DIRECTOR

Nick Deering

Nick.Deering@capacitytrucks.com

903.931.9193

WARRANTY

WARRANTY ADMINISTRATOR

Bresha Randle

Bresha.Randle@capacitytrucks.com

903.475.0620

ACCOUNTING

ACCOUNTS PAYABLE

AP@capacitytrucks.com

TECHNICAL SUPPORT TEAM

TECH SUPPORT – 800.458.3238

Cliff Huff

Cliff.Huff@capacitytrucks.com

Mike Yates

Mike.Yates@capacitytrucks.com

Danals Dunavan

Danals.Dunavan@capacitytrucks.com



DEALER SUCCESS FACTORS

DEALER SUCCESS FACTORS

DEALER SUCCESS FACTORS



Dealer Success Factors

Capacity has determined over the years that there are certain characteristics that successful dealers exhibit:

- 1) A well-thought-out strategy and business plan for the Capacity product line which includes:
 - a. New truck sales – stock trucks as well as made to order
 - b. Used truck sales – taking in trades, buying on the market or from customers
 - c. Robust service capability for Capacity and all manufacturers
 - i. Mobile service
 - ii. Cummins certification
 - d. Parts – both stocking and predictive
 - e. Rental fleet – to fill the gap between order and delivery of new as well as to fill the immediate need for breakdowns/maintenance, etc.
 - f. Full-service lease fleet – provider for customers as a one-stop shop for their terminal tractor needs
- 2) Market awareness – understanding the opportunities in your AOR as well as the competition that currently exists in the area. Identification of large distribution points/centers, fleets, rail yards, large shippers, freight break bulks, etc.
- 3) Dedicated Capacity salesperson – vital to having a honed approach to the pursuit as well as the working knowledge to be a subject matter expert on terminal tractors
- 4) Capacity marketing – utilizing the Capacity logo and brand to advertise and promote
 - a. Signage – at your dealership on the building, sign or placard
 - b. Website – logo usage and in posted advertising for trucks
 - c. Point of sale collateral
- 5) Financing/floor planning partner – leveraging the financing windows for floor planning and offering to buyers
- 6) Multiyear expansion plan – have a plan on what lines of business you are pursuing: sales, leasing, renting, etc., and have the support of that plan written and communicated; order trucks in a proactive manner to meet growth goals, set up for success
- 7) Dealer networking – identifying Capacity dealers around the world and establishing a working relationship with them is key. A cohesive approach allows any Capacity buyer to have support in every market. The Capacity network can help dealer business by leveraging marketplace knowledge, sharing best practices, helping to identify opportunities and more.



DEALER POLICIES & PROCEDURES

DEALER POLICIES & PROCEDURES

Payment & Shipment Options

Default payment terms are **half at time of order, and balance prior to shipping or per terms established by Capacity accounting and defined on the Sales Order Acknowledgment (SOA).**

Irrespective of an Authorized Dealer's credit rating or payment performance, all vehicles must be paid for by one of the following methods:

- 1) Payment by wire or collected funds check (**REFERENCE CAPACITY PAYMENT INSTRUCTIONS**)
- 2) Dealer-arranged floor plan through a third-party finance company (*preferred*)
- 3) Capacity will offer an early-pay incentive of \$650 per truck. Payment **MUST** be RECEIVED 14 days prior to invoice due date. This cannot be an invoice credit but will be paid within 30 days of invoice payment receipt. *If dealer has a Capacity-supported floor plan arrangement, the early-pay incentive does not apply.*

**Capacity offers floor plan options with DLL and provides 90 days interest-free.*

All Shipments are **FOB** Longview, Texas. Capacity can arrange freight, or authorized dealers can arrange their own transportation.

To receive the Manufacturer Statement of Origin (MSO), payment in full must be received by Capacity. Under no circumstances will Capacity release the MSO if the truck has not been paid in full.

Changes to Existing Orders

Capacity will accept changes to existing orders under certain conditions. Any change to an existing order will carry a change fee.

- 1) Outside 150 days **of the planned production start date**, Capacity will consider changes to components, drive trains and models. All change requests are subject to component lead times. A change fee of between \$150 and \$500 *per truck*, plus credits/charges as a result of the change, will be assessed on all approved change requests. The amount of the change fee will be determined at the time of request and will be gauged by the complexity of the change request.
- 2) Should a change request be made and approved *within* the 150-day window (**of the planned production start date**), a Truck Change Order (**TCO**) is required. The TCO is used when the requested changes can be accomplished during the production/assembly process and will require a change fee of \$150-\$500, plus the credits/charges as a result of the change. This change fee will be assessed at the time the TCO is approved.

**Due to current supply chain constraints, Capacity will not guarantee that changes inside the 150 days can be accomplished. They will be assessed on a case-by-case basis and communicated to the dealer or customer on order.*

Truck Cancellation Policy

Our policy on cancellation is as follows:

- 1) Within 150 days of the expected production start date, **Capacity cannot accept cancellations.**
- 2) Cancellations will only be considered for orders greater than 180 days of the expected production start date; a cancellation will be accepted with a **\$2,500 per truck** cancellation fee, along with the cost of any components unique to the truck build being canceled.
 - a. Capacity will provide a quote for the canceled components, and the fee in total will be due to Capacity within *10 days of cancellation*.

Conquest Incentive - \$1,500*

Capacity will reward a dealer for winning business from a conquest (competitor) account. This incentive must be prequalified by Capacity.

*Capacity will issue, via **ACH**, \$1,500 per truck sold in the initial sale order. Monies should be expected within 30 to 60 days of all criteria being met (submitted and approved).

The form and supporting documents **MUST** be submitted no later than 60 days from the conquest invoice. No conquest requests will be considered after the 60-day window.

Co-Op Advertising

Capacity will assist with advertising expenses of the dealer through this co-op program.

Capacity will pay 50% of the cost, up to 0.05% of the previous year's sales (trucks and parts). Capacity must approve advertising prior to publishing or printing. Payout calculation is reduced by 50% per each manufacturer listed in the advertisement.

If it is a recurring expense, please provide a copy of the ad along with your invoice.

All co-op expenses and invoices must be received by Capacity no later than Dec. 15 for them to be considered in the current fiscal year (Jan. 1 – Dec. 31).

Please contact your assigned Account Manager to provide you with the allotment for the coming fiscal year.

Ship In/Delivery Allowance

Capacity will pay a dealer \$250 per truck for any trucks shipped into that dealer's AOR. In order to receive these funds, the dealer must complete the **SHIP-IN FORM**. This is to compensate the dealer for the "HANDSHAKE" between the end-user and the local dealer.

Capacity expects dealers delivering trucks outside of their assigned AOR (per executed dealer agreement) to compensate the dealer responsible for the destination AOR \$250 per unit.

Capacity will not police this expectation. This compensation is in consideration of the support provided by the destination dealer.



WARRANTY

WARRANTY

MANUFACTURER'S LIMITED WARRANTY FOR THE CAPACITY TRUCKS PRODUCT LINE – MANUFACTURED BY Capacity Trucks, Inc.

Revised: 2026

Dear Capacity Trucks Customer,

Welcome to your new Capacity Truck. We thank you for your decision to purchase this world-class product. This document outlines the warranty coverage offered with every new Capacity Truck. For more information or to register your warranty, go to www.capacitytrucks.com. For any questions regarding your coverage, please call 800.458.3238 or email Capacity Trucks at capacityparts@capacitytrucks.com. When requesting a warranty, a Claim Reference Number (CRN) will be issued.



DEFINITIONS OF WARRANTY

Capacity Warranty - This is the warranty provided by Capacity Trucks for all Capacity components, body structure and assembly of the finished Capacity Trucks Product (the "Product") and is comprised of the following:

- **Capacity Trucks Basic New Vehicle Limited Warranty (2 years or 6,000 hours)** – the standard warranty covering the first Purchaser for the original approved application within the terms outlined later in this document.
- **Capacity Trucks Mainframe & Boom Limited Warranty (7 years or 25,000 hours)** – the warranty covering the mainframe structure of the finished Product under the terms outlined later in this document. This warranty is offered to the first Purchaser only and for the original approved application.
- **Capacity Trucks Paint Limited Warranty (3 years or 9,000 hours)** – the warranty covering the exterior paint on the finished Product. This coverage is applicable to the first Purchaser only and is prorated after 12 months. Specific warranty details are described later in this document.
- **Third Party Limited Warranty** – these are warranties provided on specific systems or components installed on the Capacity Trucks Product that remain warranted by the component supplier. For example, these items may include engines and transmissions, where the supplier provides service and support directly to the end-user.
- **Product** – all vehicles, parts and components manufactured by Capacity of Texas Inc. d/b/a Capacity Trucks, a wholly owned subsidiary of Terex Corporation.
- **Purchaser** – the individual, company or other legal entity that purchases, at retail, a new Capacity Truck Product as the end-user, either from an authorized Capacity Trucks Dealer or directly from Capacity.



WARRANTY POLICY UPDATES

- **Towing & Travel:** 2 hours each way at \$125 per hour (\$500)
 - Anything higher requires prior approval
- **Diagnostics:** 2 hours at agreed-upon shop rate
- **Warranty Orders:**
 - Parts (if in stock), Capacity pays cost plus 30%
 - If parts are not in stock, Capacity parts will ship at \$0 cost
- **Emission System:** 5-year warranty update
 - On-highway vehicles, 5-year, 100,000-mile warranty on DEF headers, lines and control valve
 - Off-highway vehicles, 5-year, 3,000-hour warranty on DEF headers, lines and control valve
 - Includes electrical components: DEF tank, DEF QLS, coolant level sensor, OEM engine harness and after-treatment fuse box
- **OEM Component Warranty:** specific details are described later in this document



STANDARD WARRANTY TERMS

Capacity Trucks Comprehensive Warranty Coverage

The Capacity Trucks Basic New Vehicle Limited Warranty period runs for two years from the original date of retail purchase by the Product's first Purchaser for the original approved application, or for 6,000 hours, whichever occurs first. This covers Capacity-made products.

Capacity Trucks provides additional coverage for those components defined under the Capacity Trucks Mainframe and Boom Limited Warranty outlined herein for a period of seven years from the original date of retail purchase by the Product's first Purchaser for the original approved application, or 25,000 hours, whichever occurs first.

Limitations: modifications and welding to the frame voids warranty. Repairs must be made by a Capacity authorized service provider, with some exceptions for certified internal repairs.

Capacity Trucks provides additional coverage for exterior paint on the finished Product defined under the Capacity Trucks Paint Limited Warranty outlined herein for a period of three years and prorated after the first year from the original date of retail purchase by the Product's first Purchaser.

During these specified warranty periods, Capacity Trucks agrees to provide coverage for parts and labor to perform repairs necessary subject to the items and limitations of this warranty agreement. Specific warranty details are described later in this document within the sections "**What is Covered by this Warranty**" and "**What is Not Covered by this Warranty.**"

Third-Party Warranty

In certain instances, components such as engines and transmissions are installed during the manufacturing process but are covered by their own distinct manufacturer warranties. While Capacity Trucks Customer Care will provide reasonable assistance in coordinating warranty support, these components shall be warranted solely by the respective supplier in accordance with the terms and conditions of that supplier's warranty. Such coverage shall not be the responsibility of Capacity Trucks. The applicable supplier warranty documentation will be provided with each new Capacity Trucks product and will also be made available upon request.



CAPACITY TRUCKS WARRANTY STATEMENT

Capacity Trucks warrants each new Product will be free of defects in materials and workmanship used during the manufacturing process. Warranty coverage is provided based on ordinary use and service within the expressed time and operational hour limits set forth herein. In the event your vehicle requires repairs, the following terms and conditions shall apply:



WARRANTY TERMS AND CONDITIONS

The following Terms and Conditions apply to all Capacity Trucks warranties described herein:

Disclaimer of Warranty

THE FOREGOING WARRANTIES ARE IN LIEU OF ALL OTHER WARRANTIES, EXPRESS OR IMPLIED, INCLUDING BUT NOT LIMITED TO THE IMPLIED WARRANTIES OF MERCHANTABILITY AND FITNESS FOR A PARTICULAR PURPOSE.

WARRANTY



Limitation of Remedies

In no case shall Capacity Trucks be liable for any special, incidental or consequential damages based upon breach of warranty, breach of contract, negligence, strict tort or any other legal theory. Such damages include, but are not limited to, loss of profits, loss of savings or revenue, loss of use of the truck or any associated equipment, cost of capital, cost of any substitute truck, equipment, facilities or services, downtime, the claims of third parties including customers and injury to property. This limitation does not apply to claims for personal injury. In the event this provision is held to be invalid, illegal or unenforceable in any respect, such invalidity, illegality or unenforceability will not affect any other provision of this Warranty, but this Warranty will be construed as if such invalid, illegal or unenforceable provision or provisions had never been contained herein.

Warranty Claim Procedure

The Purchaser must notify Capacity Trucks Customer Care, or an authorized Capacity Trucks Warranty Provider, of a potential Warranty Claim prior to the initiation of any warranty work. Within a reasonable time of receipt of the notification, Capacity Trucks, or its authorized Warranty Provider, will provide the Purchaser with further instructions on how to proceed with such warranty claim. If a non-authorized service center must be used for warranty work, the same process as an authorized Capacity Trucks Provider must be followed and estimates must be provided prior to the initiation of any warranty work. Any notice of a warranty claim and all other warranty correspondence must be submitted online at www.capacitytrucks.com or sent to Capacity Trucks, 401 Capacity Drive, Longview, TX 75604, Attn: Product Services. Capacity Trucks may designate new contact instructions and will notify the Purchaser in the event of such change.

Time Limit for Bringing Suit

Any action for breach of warranty must commence within 24 months following registered in-service date of the Product or within one month following the first 6,000 hours, whichever occurs first. If the Product is not registered, the warranty period will commence on the ship date from Capacity Trucks or the original date of retail purchase by the Product's first Purchaser, whichever occurs first.

No Other Warranties

Unless modified in writing and signed by both parties' authorized representatives, this agreement is understood to be the complete and exclusive agreement between the parties, superseding all the prior agreements, oral or written, and all other communications between the parties (including without limitation any terms and conditions contained in any purchase order or sales invoice issued pursuant to the sale of this truck) relating to the subject matter of this agreement. No employee of Capacity Trucks or any other party is authorized to make any warranty in addition to, or in lieu of, those made in this agreement.

WARRANTY



Approved Application.

The original approved application is defined below. The approved application will be documented in the final Sales Order Agreement.

Model	Approved Application	Duty-Cycle	Loading/GCWR	Surface Condition
TJ5000	Intermodal	3 shifts	Medium (Up to 81,000 lbs.)	Rough (Potholes, Railroad Crossings)
TJ6500	Warehouse/Distribution	1, 2 or 3 shifts	Street-Legal Loads, Light (Less than 125,000 lbs.)	Good
TJ9000	Port	Intermittent	Heavy (Up to 242,000 lbs.)	Rough (Potholes, Railroad Crossings)
Sabre 5	Warehouse/Distribution	1, 2 or 3 shifts	Street-Legal Loads, Light (Less than 81,000 lbs.)	Good

Warranty Registration

Warranty Registration is required to activate coverage on new Products. Upon receipt of a Capacity Trucks Product, and within 14 days of delivery, Purchaser is required to submit the final Product acceptance and warranty registration online at www.capacitytrucks.com. The Product registration must be on file for any warranty claim to be considered, otherwise the Product ship date from Capacity Trucks or the original date of retail purchase by the Product's first Purchaser, whichever occurs first, will be used as a proxy for the start of the warranty period.



CAPACITY TRUCKS BASIC NEW VEHICLE WARRANTY

1. What is Covered by This Warranty

Capacity Trucks Basic New Vehicle Warranty provides coverage for the first Purchaser for the original approved application, beginning on the original date of retail purchase, Limited Warranty period runs for two years from the original date of retail purchase by the Product's first Purchaser, or for 6,000 hours, whichever occurs first. Capacity Trucks warrants that the Product and all other original components manufactured by Capacity Trucks are free from defects in materials used and workmanship during manufacturing.

If, within any of the applicable Capacity Trucks warranty periods, a defect in material or workmanship is discovered, the Purchaser shall contact Capacity Trucks Customer Care, or an authorized Capacity Trucks Warranty Provider, for inspection and warranty claim authorization before proceeding with repairs. In no event shall such notification be received later than one month after the applicable warranty period or one month after the applicable hours, whichever occurs first.

Within a reasonable time of receipt of such notification, Capacity Trucks will work to correct any covered defect in material or workmanship with either new or used replacement parts, at Capacity Trucks' option. Such repair, including both parts and labor, is at Capacity Trucks' expense. The following are included under this warranty: Boom Lift, Cab Structure, Emission Control System and I/O Module.

OEM Component Warranty

Components that are not designated as wear and serviceable items (examples of wear and serviceable items are listed later in the document) and do not fall under a Third-Party Warranty shall carry a limited warranty not to exceed the standard truck warranty period of two years or 6,000 operating hours, which covers both parts and labor. Extended warranties are available to be purchased for up to three years or 9,000 hours.

2. What is Not Covered by This Warranty

Capacity Trucks does not warrant the following:

- Damage caused by use of the truck for purposes other than those for which it was designed.
- Damage caused by use of the truck in applications other than those approved at point of sale.
- Damage caused by accident or the negligence of the Purchaser or any third party.
- Damage caused by disasters such as fire, flood, wind, lightning, acid rain or industrial fallout.
- Damage resulting from misuse, accidents or environmental conditions—including sand, salt, road debris or tree sap—is also excluded from warranty consideration.
- Damage caused by the Purchaser’s failure to provide normal preventive maintenance as customarily accepted in the industry or as set forth in maintenance guidelines.
- Filters, belts, batteries, bushings or other parts which are a part of normal maintenance replacement.
- Damage caused by unauthorized or improper installation of attachments, inadequate maintenance, repairs, modifications or alterations.
- Damage caused by replacement of original parts or components with unauthorized substitutes.
- Damage during shipment.
- Any abuse or misuse by the Purchaser or Operator.
- Towing, rentals, travel expenses or loss of revenue.
- Damage caused by exposure to contaminants, corrosives, chemicals, irradiation or environmental or atmospheric conditions.
- All claims relating to tires; such claims are solely the responsibility of the manufacturer.
- Any export documentation fees, preparation costs or special packaging requirements.
- If a truck is submitted for warranty repair and no defect is found, or the reported condition cannot be replicated, the repair may be determined to be non-warrantable.
- Warranty coverage is limited strictly to defects in materials or workmanship, as defined by Capacity.

Wear & Serviceable Items

The following are examples considered to be wear and serviceable items and shall be excluded from **OEM Component Warranty eligibility**. This list is representative and not all-inclusive:

Powertrain Items

- Fluids
- Lubricants
- Filters
- Gaskets
- Sensors
- Belts
- Hoses

Brake System Items

- Brake linings
- Governors
- Air dryer element
- Slack adjusters
- Brake chambers
- Purge valve

Electrical System Items

- Batteries
- Incandescent bulbs
- Fuses & relays

- | Axles | Suspension | Cab Items | Tires & Wheels |
|---------------|-------------------|------------------|---------------------------|
| - Wheel seals | - Shocks | - Wipers | - Tires |
| - Bushings | - Valves | - A/C filter | - Valve stems |
| - Kingpin | - Bushings | | - Wheels |
| - Hubs | - Valves | | |
| - Bearings | | | |
| - Fasteners | | | |

CAPACITY TRUCKS MAINFRAME & BOOM LIMITED WARRANTY

The Capacity Trucks Mainframe & Boom Limited Warranty period runs for seven years from the original date of retail purchase by the Product’s first Purchaser for the original approved application, or 25,000 hours, whichever occurs first. Capacity Trucks warrants, to the first Purchaser only, the structural integrity of the mainframe and boom structure as outlined below. All claims made under the Truck Mainframe and Boom Limited Warranty require prior written authorization from Capacity Trucks Customer Care.

1. What is covered by This Warranty

“Truck Mainframe & Boom,” as defined for this warranty coverage, is limited to structural components manufactured by Capacity Trucks used to build the Product. This includes:

- Frame structure
- Boom structure

2. What is Not Covered by This Warranty

This warranty does not provide coverage for the following structural components:

- Any product, components or parts not manufactured by Capacity Trucks.
- Any unauthorized modifications may void the warranty coverage.
- Damage caused by use of the truck mainframe for purposes other than those for which it was designed.
- Damage caused by use of the truck in applications other than those approved at point of sale.
- Damage caused by accident or the negligence of the Purchaser or any third party or by disasters such as fire, flood, wind, lightning, acid rain and industrial fallout.
- Damage caused by the Purchaser’s failure to provide normal preventive maintenance as customarily accepted in the industry or as set forth in maintenance guidelines.
- Damage caused by unauthorized or improper installation of attachments, repairs, modifications or alterations.
- Damage caused by replacement of original parts or components with unauthorized substitutes.
- Damage during shipment.
- Any abuse or misuse by the Purchaser or Operator.
- Towing, rentals, travel expenses or loss of revenue.
- Damage caused by exposure to contaminants, corrosives, salt, chemicals, irradiation or environmental or atmospheric conditions.

CAPACITY TRUCKS PAINT LIMITED WARRANTY

Capacity Trucks warrants, to the first Purchaser only, that the exterior paint is free from defects in material and workmanship and further warrants that the truck body will remain free from paint defects throughout the duration of the Capacity Trucks Paint Limited Warranty period.

WARRANTY



The Capacity Trucks Paint Limited Warranty period runs for three years from the original date of retail purchase by the first Purchaser. However, after the first year, the coverage will be prorated in accordance with the schedule below:

Time Period	Coverage
≤12 months	100% materials and labor are covered
12-24 months	50% materials and 50% labor are covered
24-36 months	50% materials and 25% labor are covered

1. What is Covered by This Warranty

The Capacity Trucks Paint Limited Warranty provided herein shall cover and extend to the following properties of the paint system:

- Loss of adhesion of the paint system resulting in rust.
- Cracking of the paint system.
- Loss of adhesion of any element of the paint system.

If Purchaser discovers a defect in material or workmanship within this warranty period, it must promptly notify Capacity Trucks Customer Care in writing. In no event shall Capacity Trucks be obligated to accept such notification unless it is received by Capacity Trucks Customer Care not later than one month following the expiration of the warranty period.

Within a reasonable time after such notification, Capacity Trucks will work to correct any defect in material or workmanship. Such repair, including both paint materials and labor, is at Capacity Trucks' expense according to the schedule listed above.

All warranty work is subject to Capacity Trucks', or its agent's, prior examination and approval and will be performed by an authorized Capacity Trucks service provider, or its agents at service centers designated by Capacity Trucks, or its paint vendor.

All costs related to transportation to and from the designated service center will be at the Purchaser's sole expense and are not included as a cost of repair covered by this warranty. These remedies are the Purchaser's exclusive remedies for breach of warranty.

2. What is Not Covered by This Warranty

Capacity Trucks does not warrant:

- Exterior finish on trim or any fiberglass components, including but not limited to hardware moldings, windows, mirrors, lights and other appointments and accessories.
- Any product finishes, component finishes or finishes of parts not manufactured by Capacity Trucks.
- Damage caused by use of the truck for purposes other than those for which it was designed.
- Damage caused by use of the truck in applications other than those approved at point of sale.
- Damage caused by accident or the negligence of the Purchaser or any third party.
- Damage caused by disasters such as fire, flood, wind, lightning, acid rain and industrial fallout.
- Damage caused by the Purchaser's failure to provide normal preventive maintenance as customarily accepted in the industry or as set forth in maintenance guidelines.
- Damage caused by unauthorized or improper installation of attachments, repair, modifications or alterations.
- Damage caused by replacement of original parts or components with unauthorized substitutes.
- Damage during shipment.

- Damage caused by abrasion or external foreign objects.
- Decals, stickers, name plates, pin stripes or damage caused by application or removal of the same.
- Damage resulting from dissimilar metal contact corrosion or crevice corrosion.
- Any abuse or misuse by the Purchaser or Operator.
- Towing, rentals, travel expenses or loss of revenue.
- Damage caused by exposure to contaminants, corrosives, salt, chemicals, irradiation or environmental or atmospheric conditions.
- Damage caused by adhesive decals, vinyl wraps or other non-factory graphic installations.

WARRANTY CLAIM PROCESS

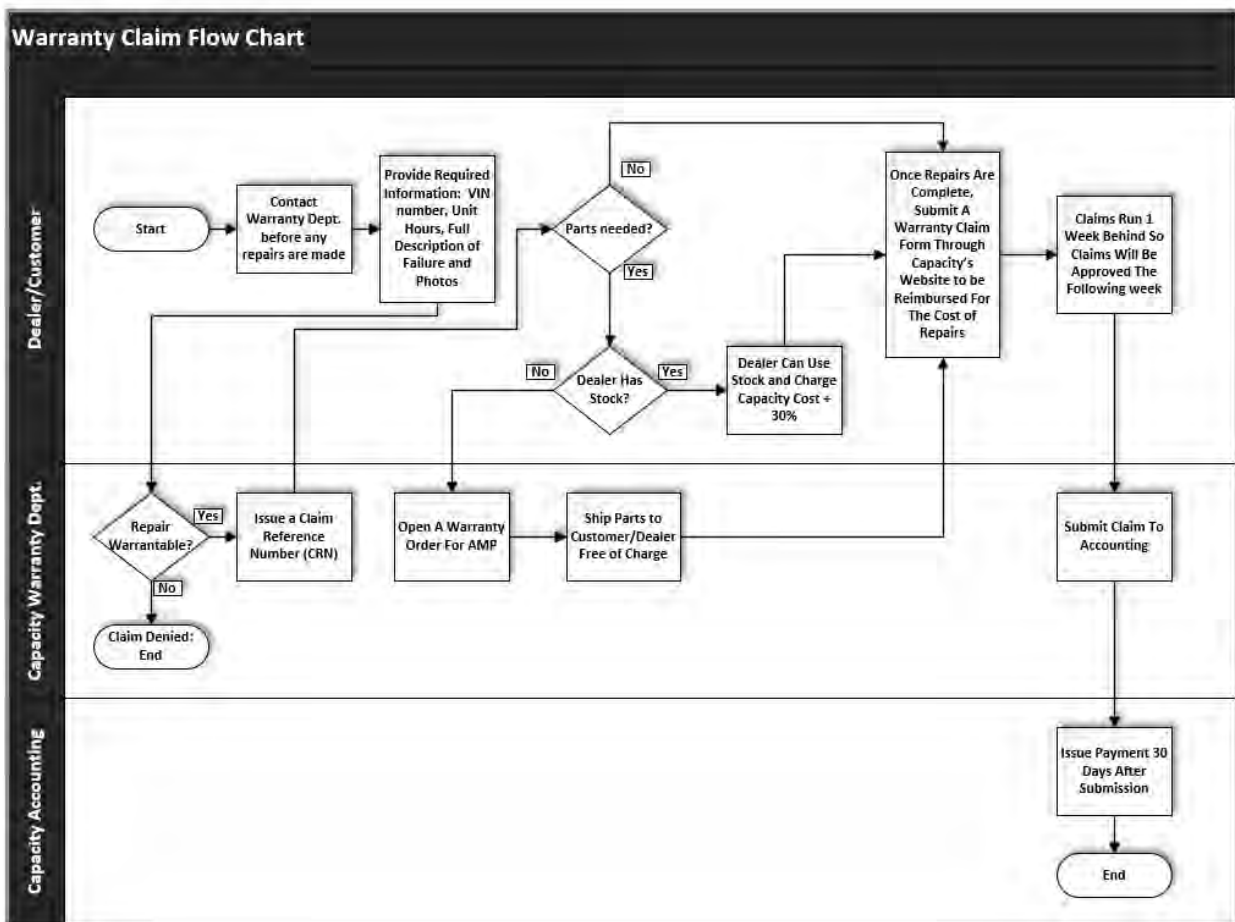



CAPACITY BASE TRUCK SPECIFICATIONS

CAPACITY BASE TRUCK SPECIFICATIONS



TJ 5000

THE "ORIGINAL" TRAILER JOCKEY

THE STANDARD – DURABILITY AND PERFORMANCE

Whether you're on the road or in the yard, you can count on the TJ 5000 to get the **JOB DONE** efficiently and effectively. Ideal for warehouse and distribution applications, the *TRAILER JOCKEY* outperforms and outlasts the competition.

Now add in the Capacity DURA-RIDE® suspension, and you now have **PERFORMANCE, RIDE** and **COMFORT** for a satisfying day in the saddle of the TJ 5000.



**PERFORMANCE
THROUGH UPTIME**

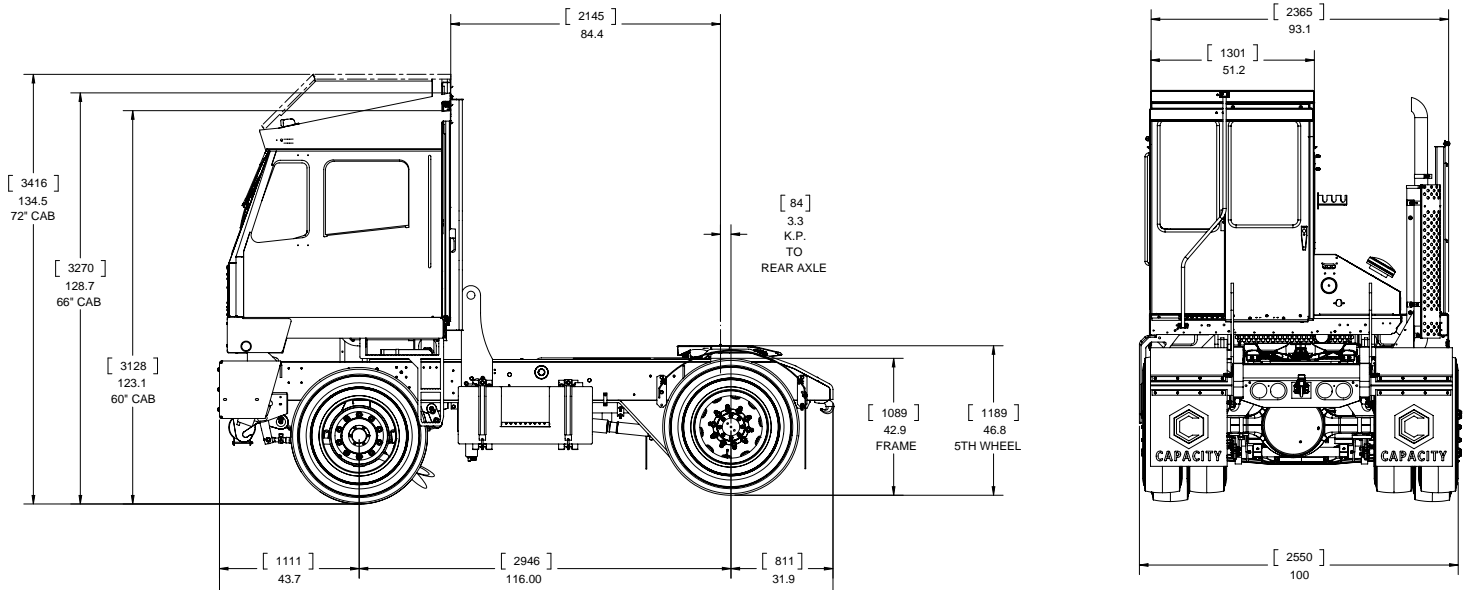

SPECIFICATIONS

Engine	Cummins ISB6.7L 200 Horsepower, 2400 RPM Turbocharged and Charge Air Cooled; Cummins 6.7 TF4 164 Horsepower	Cab	66" Ergo Cab, All-Steel Construction
Transmission	Allison RDS 3500	Cab Suspension	4-Point Air Ride Cab
Front Axle	Meritor FF-961 12,000 lbs. Capacity	HVAC	Air Conditioning w/45,000 BTU Heater/Defroster
Rear Axle	Meritor RS24-160 7.17:1 Ratio, 30,000 lbs. Terminal Rating	Electrical	12V, Multiplex Electrical System
Suspension	Dura-Ride® Air Suspension or Rigid Suspension	Telematics	CapacityVision™ Telematics
5th Wheel	SAF Holland FW35TT Rated for 80,000 lbs.	Gauges	J1939 Digital Gauges
Cylinders	5" Diameter; 16" Lift Height	Worklights	LED Worklights, Marker Lights, Rear/Stop Lights and Back-Up Lights
GCVW	81,000 lbs.	PRP	CORSOL PRP, Corrosion Polymer Coating
Frame	Fully Welded Structural "C" Channel	Paint	5-Year, Prorated Paint Warranty
Warranty	2-Year/6,000-Hour Warranty (whichever occurs first)	Frame Warranty	7-Year/25,000-Hour (whichever occurs first)



TJ 6500

THE "ORIGINAL" TRAILER JOCKEY

A SERIOUS WORKHORSE!

Introducing the TJ 5000's **BIGGER BROTHER**...we took the **INDUSTRY STANDARD** and added an additional axle. The TJ 6500 is the ideal **TRAILER JOCKEY** for less-than-ideal road/yard conditions. Whether you're transferring trash from the transfer station to the landfill or just need **MORE TRACTION, CONTROL** and **STABILITY**, choose TJ 6500 to get the **JOB DONE!** It's a reliable workhorse for the day-to-day, on-road and off-road operations.



CAPACITY[®]

**YOUR
PLUS ONE**

Capacity is ISO 9001 Certified.

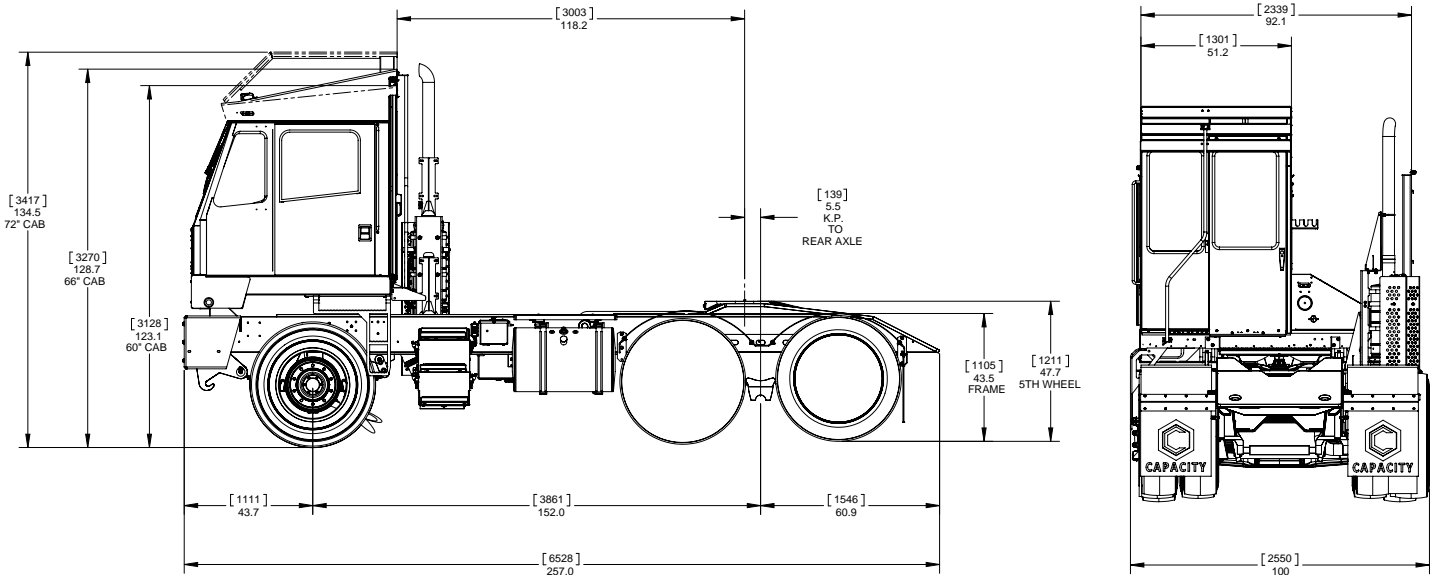

SPECIFICATIONS

Engine	Cummins® ISB6.7L 200 Horsepower, 2400 RPM Turbocharged and Charge Air Cooled; Cummins 6.7 TF4 173 Horsepower	Cab	66" Ergo Cab, All-Steel Construction
Transmission	Allison RDS 3500	Cab Suspension	4-Point Air Ride Cab
Front Axle	Meritor® FF-961 12,000-lb. Capacity	HVAC	Air Conditioning w/45,000 BTU Heater/Defroster
Rear Axle	Tandem Meritor MT44-145 7.17:1 Ratio, 40,000 lbs. Terminal Rating	Electrical	12V, Multiplex Electrical System
Suspension	Hendrickson® Tandem Suspension	Telematics	CapacityVision™ Telematics
5th Wheel	SAF Holland® FW35TT Rated for 80,000 lbs.	Gauges	J1939 Digital Gauges
Cylinders	5" Diameter; 16" Lift Height	Worklights	LED Worklights, Marker Lights, Rear/Stop Lights and Back-Up Lights
GCVW	121,000 lbs.	PRP	CORSOL PRP, Corrosion Polymer Coating
Frame	Fully Welded Structural C-Channel	Paint	5-Year, Prorated Paint Warranty
Warranty	2-Year/6,000-Hour Warranty (whichever occurs first)	Frame Warranty	7-Year/25,000-Hour Warranty (whichever occurs first)



TJ 9000

THE "ORIGINAL" TRAILER JOCKEY

PURE MUSCLE!

THE ULTIMATE POWER PLAYER, designed for maximum uptime. From the one-piece structural steel frame to the interior of the all-steel cab, every aspect of the TJ 9000 is engineered to meet the needs of the **BIGGEST JOBS!**

The TJ 9000 is ideal for extra-heavy-duty applications, capable of moving up to 180,000 pounds. Whether on the road or in the yard, when you add the industry-exclusive Capacity DURA-RIDE® suspension, you now have **THE MUSCLE** plus a satisfying day in the saddle!



CAPACITY®

**MOUNTAIN
OF MUSCLE**

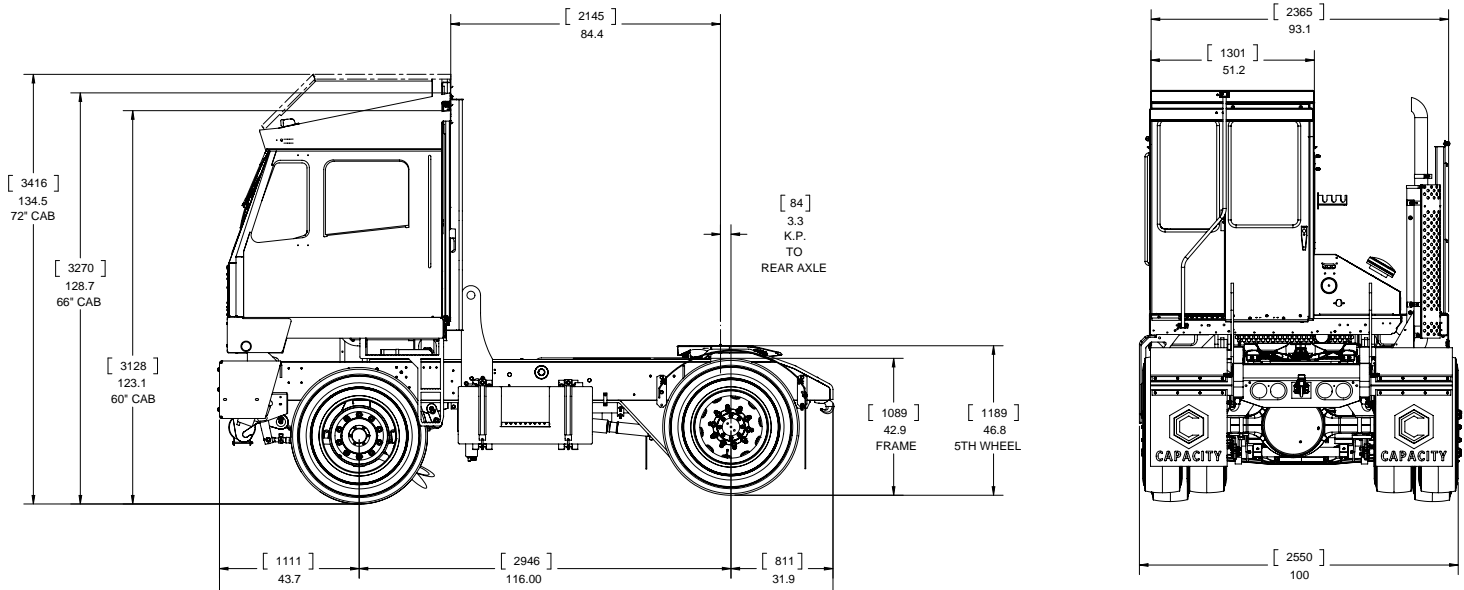

SPECIFICATIONS

Engine	Cummins® ISB6.7L 200 Horsepower, 2400 RPM Turbocharged and Charge Air Cooled; Cummins 6.7 TF4 173 Horsepower	Cab	66" Ergo Cab, All-Steel Construction
Transmission	Allison RDS 3500	Cab Suspension	4-Point Air Ride Cab
Front Axle	Meritor® FL-941 16,000-lb. Capacity	HVAC	Air Conditioning w/45,000 BTU Heater/Defroster
Rear Axle	Meritor MOR-32 12.28:1 Ratio, 70,000 lbs. Terminal Rating	Electrical	12V, Multiplex Electrical System
Suspension	Rigid or DURA-RIDE® Suspension	Telematics	CapacityVision™ Telematics
5th Wheel	SAF Holland® FW35TT Rated for 80,000 lbs.	Gauges	J1939 Digital Gauges
Cylinders	5" Diameter; 16" Lift Height	Worklights	LED Worklights, Marker Lights, Rear/Stop Lights and Back-Up Lights
GCVW	Up to 180,000 lbs.	PRP	CORSOL PRP, Corrosion Polymer Coating
Frame	Fully Welded Structural C-Channel	Paint	5-Year, Prorated Paint Warranty
Warranty	2-Year/6,000-Hour Warranty (whichever occurs first)	Frame Warranty	7-Year/25,000-Hour Warranty (whichever occurs first)



TJ 5000

THE "ORIGINAL" TRAILER JOCKEY

FUELED BY LPG AND CNG

THE STANDARD – DURABILITY AND PERFORMANCE

Whether you're on the road or in the yard, you can count on the TJ 5000 to get the **JOB DONE** efficiently and effectively. Ideal for warehouse and distribution applications, the *TRAILER JOCKEY* outperforms and outlasts the competition.

Add in the Capacity DURA-RIDE® suspension, and you now have **PERFORMANCE, RIDE** and **COMFORT** for a satisfying day in the saddle of the TJ 5000.

We offer a range of fuel types for our Trailer Jockeys to meet your alternative energy needs.



CAPACITY

**PERFORMANCE
THROUGH UPTIME**

Capacity is ISO 9001 Certified.



LPG SPECIFICATIONS

Engine	PSI Off Road LPG, 8.8L V8, 265 HP, 553 ft. lbs. Torque. Spark Ignited, Naturally Aspirated, Provides Comparable Performance to Similar Diesel Engine, Significant Fuel Savings While Idling, 2 Ultra-low Catalytic Converters
Eng. Warranty	2 Years or 2,500 Hours
Transmission	Allison RDS 3500
Front Axle	Meritor FF-961 12,000 lbs. Capacity
Rear Axle	Meritor RS24-160 7.17:1 Ratio, 30,000 lbs. Terminal Rating
Wheel Base	136"
Suspension	Dura-Ride® Air Suspension or Rigid Suspension
Fuel Tanks	2 40-Gallon Propane (Water Equivalent) Tanks
5th Wheel	SAF Holland FW35TT Rated for 80,000 lbs.
Cylinders	5" Diameter; 16" Lift Height
GCVW	81,000 lbs.

Frame	Fully Welded Structural "C" Channel
Warranty	2-Year/6,000-Hour Warranty (whichever occurs first)
Cab	66" Ergo Cab, All-Steel Construction
Cab Suspension	4-Point Air Ride Cab
HVAC	Air Conditioning with 45,000 BTU Heater/Defroster
Electrical	12V, Multiplex Electrical System
Telematics	CapacityVision™ Telematics
Gauges	J1939 Digital Gauges
Worklights	LED Worklights, Marker Lights, Rear/Stop Lights and Back-Up Lights
PRP	CORSOL PRP, Corrosion Polymer Coating
Paint Warranty	5-Year, Prorated Paint Warranty
Frame Warranty	7-Year/25,000-Hour Warranty (whichever occurs first)



CNG SPECIFICATIONS

Engine	Cummins B6.7N 6.7L 200 HP 520 ft. lbs. Torque, Turbocharged, CAC
Eng. Warranty	2 Years, Unlimited Hours
Transmission	Allison RDS 3500
Front Axle	Meritor FF-961 12,000 lbs. Capacity
Rear Axle	Meritor RS24-160 7.17:1 Ratio, 30,000 lbs. Terminal Rating
Wheel Base	128"
Suspension	Dura-Ride® Air Suspension or Rigid Suspension
Fuel Tanks	Agility 21 Diesel Gallon Equivalent CNG
5th Wheel	SAF Holland FW35TT Rated for 80,000 lbs.
Cylinders	5" Diameter; 16" Lift Height
GCVW	81,000 lbs.

Frame	Fully Welded Structural "C" Channel
Warranty	2-Year/6,000-Hour Warranty (whichever occurs first)
Cab	66" Ergo Cab, All-Steel Construction
Cab Suspension	4-Point Air Ride Cab
HVAC	Air Conditioning with 45,000 BTU Heater/Defroster
Electrical	12V, Multiplex Electrical System
Telematics	CapacityVision™ Telematics
Gauges	J1939 Digital Gauges
Worklights	LED Worklights, Marker Lights, Rear/Stop Lights and Back-Up Lights
PRP	CORSOL PRP, Corrosion Polymer Coating
Paint Warranty	5-Year, Prorated Paint Warranty
Frame Warranty	7-Year/25,000-Hour Warranty (whichever occurs first)



AFTERMARKET PARTS

AFTERMARKET PARTS



TERMS & CONDITIONS

- All terms are net 30 days, unless specifically identified on the Capacity invoice
- All shipments are FOB Longview, Texas
- All prices are in U.S. dollars
- It is Capacity's goal and objective to ship standard ground orders within one business day of order receipt. This is not a guarantee; we will do everything we can to continue to improve our ability to do so every day. Orders will be shipped in the following priority:
 - Warranty/Unit Down
 - Next-Day Air/Expedited Shipments
 - Standard Ground/LTL Freight Orders: If your order is available to ship, you can pay a \$50 Special Handling Fee to ensure it goes to the front of the *regular order* line. It will not be put ahead of a warranty or next-day orders, and a CSR must be notified of this request once order is placed
- Dealer Stock Orders are shipped prepaid if order is \$5,000 or greater
 - Exclusions from this prepaid freight offer include cabs, frames, booms, axles, 5th wheels, boom cylinders and any other larger/heavier parts (at manager's discretion)
 - Time to ship a Stock Order is 3-4 business days
 - Stock Orders over \$50,000 are 5-10 business days
 - Unless otherwise directed, available parts will ship, and unavailable parts will ship when they become available at no additional cost
 - Prepaid freight stock orders are **ONLY** shipped to the ordering Capacity dealer's location, NEVER to anyone else
 - Shipping method must be marked as **Dealer Stock Order** when these orders are placed
- If a customer order states:
 - **"Ship Complete," ALL PARTS WILL SHIP WHEN ALL PARTS ARE IN STOCK**
 - **"Ship Partial,"** parts that are available in stock will ship and parts unavailable will ship WHEN they become available in stock
 - If there is NO specification of either, available parts will ship and unavailable parts will be backordered as default
- Returns
 - No returns are accepted **without a Return Goods Authorization (RGA) number**
 - RGAs can be requested via phone 800.458.3238 or via email at capacityparts@capacitytrucks.com
 - Any parts returned **without an RGA number** will be refused or returned to customer at **customer's expense**
 - **Please refer to Capacity Parts Return Policy**
- Prices and specifications are subject to change without notice. You can verify the current price and availability at <https://capacity-parts.com>.
- Any part not currently set up in the Capacity Parts System, or that does not have current pricing, will require Capacity to request such from the supplier. Capacity does not control all aspects of this process and will work through it as quickly as possible.
- **Freight damage is the dealer's responsibility to recover.** To protect the value of your shipment, Capacity will add insurance to all shipments at or over \$100 in value. If you do not want this coverage, you will be required to provide Capacity with your freight carrier collect account information and Capacity will bill against that.

AFTERMARKET PARTS



CAPACITY TRUCKS, INC. PARTS RETURN POLICY

Subject to revision at any time*		Effective March 1, 2026		
<u>TYPE OF RETURN / CREDIT REQUEST</u>	<u>RETURN REQUEST TIME LIMIT</u>	<u>RE-STOCKING FEE</u>	<u>RETURN AUTHORIZATION PROCEDURE</u>	<u>FREIGHT CHARGES</u>
ORDERED IN ERROR 30 DAY RETURN	30 CALENDAR DAYS FROM RECEIPT	25% OF CURRENT DEALER NET	MUST SUBMIT CLAIM VIA PHONE WITH A CSR OR THROUGH EMAIL WITH PARTS DEPARTMENT. CAPACITY TO ADVISE RGA # BY RETURN EMAIL. SOME RESTRICTIONS APPLY. PLEASE SEE 30 DAY CONDITIONS BELOW.	DEALER TO PAY FREIGHT CHARGES
ORDERED - NO LONGER NEED - 30 DAY RETURN	30 CALENDAR DAYS FROM RECEIPT	25% OF CURRENT DEALER NET	MUST SUBMIT CLAIM VIA PHONE WITH A CSR OR THROUGH EMAIL WITH PARTS DEPARTMENT. CAPACITY TO ADVISE RGA # BY RETURN EMAIL. SOME RESTRICTIONS APPLY. PLEASE SEE 30 DAY CONDITIONS BELOW.	DEALER TO PAY FREIGHT CHARGES
CAPACITY SHIPMENT ERROR (RECEIVED WRONG PART)	30 CALENDAR DAYS FROM RECEIPT	NONE	MUST SUBMIT CLAIM VIA PHONE WITH A CSR OR THROUGH EMAIL WITH PARTS DEPARTMENT. CAPACITY TO ADVISE RGA # BY RETURN EMAIL. CUSTOMER MUST SEND PROOF OF INCORRECT PART RECEIVED. SOME RESTRICTIONS APPLY. PLEASE SEE SHIPPING ERROR CONDITIONS BELOW.	SHIPPED BACK ON CAPACITY ACCOUNT
SHORTAGE	5 CALENDAR DAYS FROM RECEIPT	NONE	MUST SUBMIT CLAIM VIA PHONE WITH A CSR OR THROUGH EMAIL WITH PARTS DEPARTMENT. CAPACITY TO ADVISE RGA # BY RETURN EMAIL. PARTS SHORTED WILL BE SENT AT NO CHARGE TO CUSTOMER.	CAPACITY SHIPS REPLACEMENT (NO EXTRA FREIGHT TO CUSTOMER)
OVERAGE	5 CALENDAR DAYS FROM RECEIPT	NONE	MUST SUBMIT CLAIM VIA PHONE WITH A CSR OR THROUGH EMAIL WITH PARTS DEPARTMENT. CAPACITY TO ADVISE RGA # BY RETURN EMAIL. SEE OVERAGE CONDITIONS BELOW.	SHIPPED BACK ON CAPACITY ACCOUNT
AFTERMARKET PARTS WARRANTY	90 DAYS FROM CAPACITY INVOICE	NONE	MUST SUBMIT CLAIM VIA PHONE WITH A CSR OR THROUGH EMAIL WITH PARTS DEPARTMENT. CAPACITY TO ADVISE RGA # BY RETURN EMAIL. SEE DEFECT CONDITIONS BELOW.	PRE-PAY TO CAPACITY - FREIGHT CREDIT ISSUED
DAMAGED ORDER/PART(S)	WITHIN 2 BUSINESS DAYS OF RECEIPT	NONE	MUST SUBMIT CLAIM VIA PHONE WITH A CSR OR THROUGH EMAIL WITH PARTS DEPARTMENT. CAPACITY TO ADVISE RGA # BY RETURN EMAIL. SEE DAMAGE CONDITIONS BELOW.	N/A
FREIGHT CHARGE DISCREPANCY	5 CALENDAR DAYS FROM RECEIPT	N/A	MUST SUBMIT CLAIM VIA PHONE WITH A CSR OR THROUGH EMAIL WITH PARTS DEPARTMENT. CAPACITY TO ADVISE RGA # BY RETURN EMAIL.	N/A
BILLING ERROR	5 CALENDAR DAYS FROM RECEIPT	N/A	MUST SUBMIT CLAIM VIA PHONE WITH A CSR OR THROUGH EMAIL WITH PARTS DEPARTMENT. CAPACITY TO ADVISE RGA # BY RETURN EMAIL.	N/A
DEALER STOCK RETURN	BI-ANNUALLY (JANUARY & JULY)	20% *	CAPACITY WILL APPROVE PARTS ALLOWABLE AND DEALER MUST SUBMIT ANY OFFSETTING ORDER AT THAT TIME.	DEALER TO PAY FREIGHT CHARGES
*DEALER STOCK RETURN CONDITIONS: Bi-Annually, there is a dealer stock return period. (January & July) Non-stocking items, manufactured parts, seal kits and hardware are not allowed. Customer Service Representative will approve the parts allowed to be returned and RGA will be issued. Parts requesting to be returned during this period must have been purchased within the last 12 months. Any parts outside of this period will be denied. There will be a 10% restocking fee WITH an offsetting order, or a 20% restocking fee WITHOUT an offset order.				
30 DAY RETURN CONDITIONS: Capacity will make final determination on return authorization. Seal kits and special order (non-stocking) items and CAPACITY fabricated/manufactured parts/kits are not returnable. Any part that is ordered and is not in the current price list is considered special order and is not returnable. All returns must be requested through the parts department 800-458-3238 or capacityparts@capacitytrucks.com. All parts must be in new and saleable condition. Any parts that are returned to CAPACITY without prior authorization or do not meet that stated return requirements will be scrapped without notification and credit denied.				
WARRANTY: 90 days from date of Capacity Invoice. Upon return and inspection of the failed part, if determined the failure is caused by faulty workmanship or material defect, you will receive a replacement or credit. Electrical, hydraulic, maintenance parts and shelf deteriorating parts are excluded from this warranty and shall be covered by the applicable warranty extended by the manufacturer of the respective parts. These parts will be returned to the respective vendors to determine by inspection if there is a defect in material or workmanship. Warranty excludes damage caused by misuse, abuse, other faulty parts, improper installation or any use other than its original function. EXCEPT AS SET FORTH HEREIN CAPACITY MAKES NO OTHER WARRANTY, EXPRESS OR IMPLIED, AND MAKES NO WARRANTY OF MERCHANTABILITY OR FITNESS FOR ANY PARTICULAR PURPOSE.				
OVERAGE CONDITIONS: A) Keep parts. A new invoice will be created to charge customer for those parts. No freight to be charged. B) Return parts by following RGA procedure. No restocking fee.				
DEFECTIVE CONDITION: See Warranty Conditions.				
DAMAGED PARTS CONDITION: If freight damage was shipped on customer's collect account number, then it is the customer's responsibility to contact the carrier and to file a claim. No credit will be issued from Capacity. If damage was on a prepay and add invoice, Capacity accepts the responsibility to contact carrier and file a claim. Credit will be issued based on findings. If part was not damaged in transit but damaged in packaging, this will be managed as a Warranty issue.				
SHIPPING ERROR CONDITION: Parts shipped in error can be advised to be scrapped at customer's location according to CSR's determination.				



BRAND USE GUIDELINES

BRAND USE GUIDELINES



BRAND GUIDELINES



USING THIS MANUAL

- 3 Overview
- 3 Who Should Use this Manual

BRAND VOICE

- | | | |
|-------------------|---------------------|-------------------------|
| 4 Brand Story | 7 Brand Pillars | 9 Words and Terminology |
| 5 Elevator Speech | 8 Brand Personality | 9 ISO Certification |
| 6 Brand Essence | 8 Brand Foundation | 10 Verticals |

CAPACITY GRAPHIC STANDARDS

- | | |
|------------------------------------|---------------------------------|
| 11 The Capacity Logo | 16 Acceptable Logo Treatments |
| 12 Placement of Essential Elements | 17 Unacceptable Logo Treatments |
| 13 Logo Forms | 18 Color Usage |
| 14 Primary Logo Area of Isolation | 19 Approved Color Palette |
| 15 Logo Size | 20 Brand Typefaces |



OVERVIEW

It is important that Capacity portrays itself in a consistent manner in all communications.

These brand guidelines provide information on the Capacity brand and how we communicate it to others. It also includes rules and proper usage of Capacity logos, taglines, artwork and colors.

There are numerous ways Capacity visually communicates with its customers and the industry:

- ADVERTISING**
- APPAREL**
- BROCHURES**
- BUSINESS CARDS**
- BUSINESS DOCUMENTS AND FORMS**
- DIGITAL MARKETING**
- DISPLAYS**
- INTERNAL COMMUNICATIONS**
- PRESENTATIONS**
- PRESS RELEASES**
- PROMOTIONAL ITEMS**
- SIGNS**
- SOCIAL MEDIA**
- STATIONERY**
- WEBSITES**

WHO SHOULD USE THIS MANUAL

Anyone creating communications for Capacity should be aware of and refer to these guidelines.

BRAND STORY

Since 1974, Capacity has been an industry leader in terminal trucks, known for our robust manufacturing, high level of customization and durable products. Today, Capacity Trucks is part of Terex Corporation, a global leader in specialized equipment solutions, serving essential sectors such as emergency services, waste and recycling, utilities, and construction.

Our dedication and collaborative spirit drive us to innovate—taking a customer-focused approach to increase efficiencies and uptime profitability, while lowering total cost of operation. At Capacity, we keep the world—and our customers—moving.



ELEVATOR SPEECH

Since 1974, Capacity Trucks has been an industry leader in terminal trucks, known for our robust manufacturing, high level of customization and durable products. With our people, relationships and products, we have the capacity to move cargo and our customers around the world.



BRAND ESSENCE

Capacity's durable yard trucks move the world's cargo, operating in the busiest ports, rail terminals and warehouse/distribution centers. With a customer-focused approach, our team inspires trust and confidence by delivering exact solutions for every need. We apply our decades of experience to continually innovate, developing new products and technologies that maximize our customers' efficiency and uptime. Every yard truck we build is backed by a nationwide dealer network dedicated to providing expert support, along with 24/7 parts availability. At Capacity Trucks, we help keep our customers and their cargo moving.



BRAND PILLARS

PERFORMANCE

Capacity Trucks keeps the world moving with durable yard trucks that perform day in and day out. From heavy-duty trucks that conquer the most challenging environments to road-friendly models, our products are expertly engineered to deliver the utmost efficiency. It's how we maximize uptime and achieve the lowest possible total cost of ownership for your business.

TRUST

At Capacity Trucks, we have an unwavering commitment to building trusted, transparent relationships with our customers and dealers. It is our mission and our pleasure to help you succeed with the right equipment built to your specifications. Our team is proud to stand with and by you, from initial collaboration to product support in the field, helping you move cargo in the most efficient way possible. That's why customers have counted on the proven expertise of Capacity Trucks since 1974.

INNOVATION

At Capacity Trucks, innovation moves us. Whether it's enhancing the longevity and durability of our products or developing industry-first operator safety features, we're exploring new and better solutions and technologies every day. It's the result of working closely with customers to understand their unique needs, then unleashing the expertise of our team to customize products that meet those needs.

QUALITY

Quality and confidence go hand in hand. We understand that at Capacity Trucks. No truck is engineered or tested to withstand the rigors of the job like a Capacity truck. Our proprietary quality assurance process results in fewer warranty claims and greater ROI for your operation. That means you can move forward with confidence every day.



BRAND PERSONALITY

Confident, Expert, Approachable

CONFIDENT IS:

Humble
Informed
Always listening
Always learning
Believing
Committed to doing the right thing
Reliable

EXPERT IS:

Collaborative
Tested
Knowledgeable
Leader
Purpose-driven

APPROACHABLE IS:

Customer-centric
Dependable
Customizable
Authentic
Team-oriented
Accessible

CONFIDENT IS NEVER:

Arrogant
Selfish
Short-sighted
Disingenuous
Rigid
Out for themselves
Dictatorial

EXPERT IS NEVER:

Closed-minded
Dated/Uninformed
Insolent
Follower
Isolated

APPROACHABLE IS NEVER:

One-way street
Complacent
Off the shelf
Insincere
Soloist
Elitist

BRAND FOUNDATION

DURABILITY

Since 1974, Capacity has stood the test of time, building its reputation upon the rugged durability of its products and the integrity of its people. Durability is the enduring bedrock and foundation that supports the Capacity brand pillars. It is this rugged durability that encompasses everything we do and everything we are, and is the reason customers rely on Capacity.

WORDS AND TERMINOLOGY

CAPACITY IS:

Capacity Trucks
Work tool
Durable
Reliable
Best
Collaborative
Approachable
On-purpose
Global
Right material
What's best and easiest for our customers
Customizable

CAPACITY IS NEVER:

Capacity of Texas
Sharpest tool in the shed
Gold Standard (Ottawa uses)
Volatile
Largest
Dictating
Condescending
Fluff
Only Texas
More material
What's convenient for us
Off the shelf

ISO CERTIFICATION

Capacity Trucks is ISO 9001:2008 certified. This fact should be noted on any materials that include product information or specifications.

VERTICALS

INTERMODAL

When every minute counts, you need a yard truck that will be there for you, delivering superior durability and uptime, every time. Capacity Trucks answers the call with products that perform in the most challenging environments. Their robust design withstands the rigors of intermodal operation while ensuring a low total cost of ownership and maximizing your return on investment.

PORT

At Capacity Trucks, we understand every customer has unique needs. That's why our team works closely with you to specialize yard trucks that meet the specific requirements of your port operation. Whether it's an industry-first innovation that ensures your drivers' safety or developing technology that makes their jobs easier, Capacity Trucks is dedicated to building products that work as hard as you do.

WAREHOUSE/DISTRIBUTION

Moving cargo at warehouse and distribution facilities requires the durability and value of a high-performing, long-lasting yard truck. Capacity Trucks gets the job done with robust products that maximize uptime and deliver low total cost of ownership. And because every operation is unique, our team works closely with you to identify any specialized needs. It's a 24/7 uptime industry, and Capacity is your 24/7 partner, delivering efficiency where it's needed most.

INTERMODAL CUSTOMER

Paid by how quickly they can complete the job

Downtime is a key concern

Drivers are higher paid than warehouse workers

Works in harsh environments

Highly price conscious

PORT CUSTOMER

Less price conscious

Interested in customization

WAREHOUSE/DISTRIBUTION CUSTOMER

Most interested in longevity of product

Attention toward driver comfort and safety

Price conscious

THE CAPACITY LOGO

The Capacity logo uses multiple colors of blue, but starts with a foundation of dark blue that invokes the heritage of Capacity and blue from the American flag. The precision of the Capacity “C” illustrates how we are moving forward as a company and a brand.

The new Capacity logo is designed to:

- Accompany the most significant launch in Capacity’s history
- Preserve bedrock recognition of Capacity
- Mark a new era of growth for Capacity Trucks
- Reflect our new invigoration and innovation

TYPEFACE

The Capacity letters have been refreshed and are designed in a progressive san serif typeface. The boldness of the san serif helps to illustrate the strength and durability of the Capacity brand.

THE DuraC



The DuraC is foundational to the Capacity brand. It is meant to represent strength through purpose-focused engineering. From weld on to bolt on, Capacity’s modular evolution means the DuraC is more appropriate than ever.

PLACEMENT OF ESSENTIAL ELEMENTS

Two essential elements make up the standard Capacity logo: the mark and the signature. The following specifications for placement of these two elements are mandatory. The specific elements should not be altered in any way. Later sections of this style guide also define the mandatory color codes. Colors from computer printouts vary, so please follow the PMS codes.



The Capacity badge is comprised of the Capacity DuraC and the Capacity signature. All letters must be capitalized.

LOGO FORMS

PRIMARY LOGO

This is the primary Capacity logo and should be used for all one- and four-color applications. If color is not the preferred option, it is also permissible to use the black or reversed logo options.



SECONDARY LOGO

The secondary logo is to be used when spatial height is limited. The secondary logo should be used for all one- and four-color applications. If color is not the preferred option, it is also permissible to use the black or reversed logo options.



TERTIARY LOGO

The tertiary logo is to be used for special executions in which the primary logo with full corporate name is not necessary. The tertiary logo cannot stand alone on a document. It must be accompanied by the primary or secondary logo. Specific exceptions may apply.



CAPACITY TRUCKS LOGO

The Capacity Trucks logo is to be used on apparel only. If color is not the preferred option, it is also permissible to use the black or reversed logo options as well.



PRIMARY LOGO AREA OF ISOLATION

When using the Capacity logo, allow for an adequate amount of space around it. This space is to be determined by measuring the height of the Capacity DuraC and marking off this distance from the outermost boundaries of the logo. To ensure readability and easy identification of the logo, no text, graphics or edges should fall within this space.

safe zone

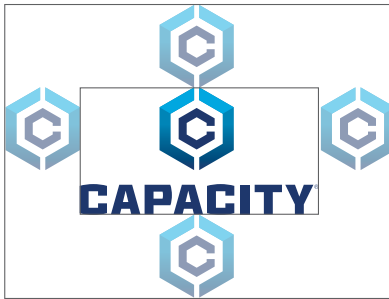

safe zone



REDUCING PRIMARY AND SECONDARY LOGO

When reducing the primary logo or secondary logo, the height of the Capacity signature should be no less than 0.125 in.



TERTIARY LOGO SIZE

When using the tertiary logo, the height of the DuraC should be no less than 0.25 in.

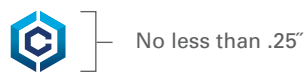

ACCEPTABLE LOGO TREATMENTS

The only acceptable uses of the Capacity logo are outlined in this manual. The Capacity logo may not be modified in any way from its original proportions or type style.

The Capacity logo should always stand alone and may never be used as part of a sentence. When used within a sentence, the name Capacity is permitted to appear as standard copy.

ONE AND FOUR COLOR



BLACK AND REVERSED



UNACCEPTABLE LOGO TREATMENTS

MODIFYING PROPORTIONS

Do not stretch the logo horizontally or vertically.

Do not skew or distort the logo.

OTHER MODIFICATIONS

Do not change the color or screen back the logo.

Do not use outlines.

Do not adjust the angle of the Capacity badge.

Do not place logo on any background unless it's a solid color or image that won't detract from its overall legibility. When used on a background, the logo should always be one of the three approved one-color, three-color or four-color versions. All other versions of the logo are to be printed on 10% gray (or less) and white only.



THREE- AND FOUR-COLOR USAGE

These logos are to be used on apparel and applications, including uncoated, coated gloss and coated matte, where CMYK color separation is required.



BLACK AND REVERSED-COLOR USAGE

These logos are to be used on all paper and fabric types where a one-color logo is required. Logo can be produced in 100% black, 100% white or PMS 288 (dark blue).





APPROVED COLOR PALETTE

PMS 288 Blue is the primary color for the Capacity identity.
100% Black is acceptable for specific executions.



APPROVED 3-COLOR PALETTE



	PMS	CMYK	RGB	Web
	PMS 2995	81-12-1-0	0-167-225	00a7e1
	PMS 7460	100-33-14-0	0-131-193	0083c1
	PMS 288	100-87-27-19	0-45-116	002d74

APPROVED 3-COLOR REVERSED PALETTE



	PMS	CMYK	RGB	Web
	PMS 2985	59-4-2-0	85-192-233	54c0e8
	PMS 2995	81-12-1-0	0-167-225	00a7e1
	PMS 288	100-87-27-19	0-45-116	002d74

BRAND TYPEFACES

The success of Capacity's corporate identity program is also dependent on the consistency of the typefaces.

When the logo is used as a graphic element, not in body copy, it is important the signature and wordmark appear in the proper typeface.



IRONSTRIKE BLACK

The primary font for the Capacity identity program is Ironstrike. Ironstrike is strong, progressive, bold and easy to read. It comes in a wide assortment of weights and is ideal for headlines and decorative font usages.

In some situations regarding different platform softwares such as Word and PowerPoint, Ironstrike cannot be used. For these situations, Verdana is the acceptable replacement for all headline and body copy. These technical constraints should be the only reason to substitute Ironstrike with Verdana.

HEADLINE/ DECORATIVE

IRONSTRIKE

Ironstrike Light
Ironstrike Light Italic

Ironstrike Semibold
Ironstrike Semibold Italic

Ironstrike Bold
Ironstrike Bold Italic

Ironstrike Black
Ironstrike Black Italic

HEADLINE ONLY

RALEWAY

RALEWAY LIGHT

RALEWAY MEDIUM

RALEWAY BOLD

BODY COPY

UNIVERS

Univers Light
Univers Light

Univers Roman
Univers Roman

Univers Bold
Univers Bold

Univers Black
Univers Black

TECHNICAL CONSTRAINTS

VERDANA

Verdana Regular
Verdana Italic

Verdana Bold
Verdana Bold Italic



401 Capacity Drive
Longview, TX 75604

Office Toll Free: 800-323-0135

Parts & Service: 800-458-3238

Email: capacityparts@capacitytrucks.com

Website: capacitytrucks.com